

Overall Dimensions

3 Product, 40 l/min, Suction Pump With Vap. Rec. & Preset

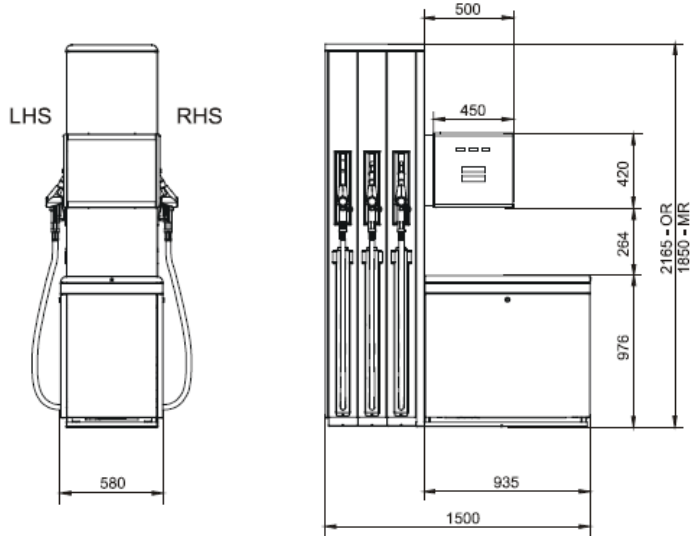

Valid only for C+ and Ecometer versions.
Not for Multiplexed Ecometer

Dimensions are in Millimetres

Option: Suction connection kit
140 826 683 without cathodic protection
140 826 693 with cathodic protection

Footprint Details Riht Side of Dispenser (RHS)

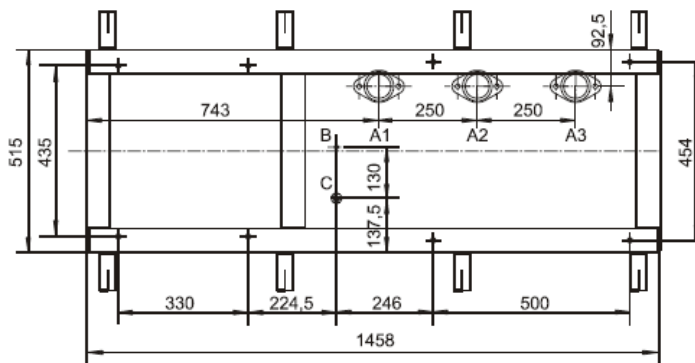

Subframe
Part No. - 140 733 662

Key to Symbols
A1- A3 - Grade 1, 2, 3
B - Cable Riser
C - Vapour Recovery

It is recommended that Vapour Recovery return pipes are installed where this may be a future requirement.

Module Configuration

Right Hand Side of Dispenser

