

Overall Dimensions

**4 Product, 40 l/min, Suction Pump
With Vap. Rec. & Preset**

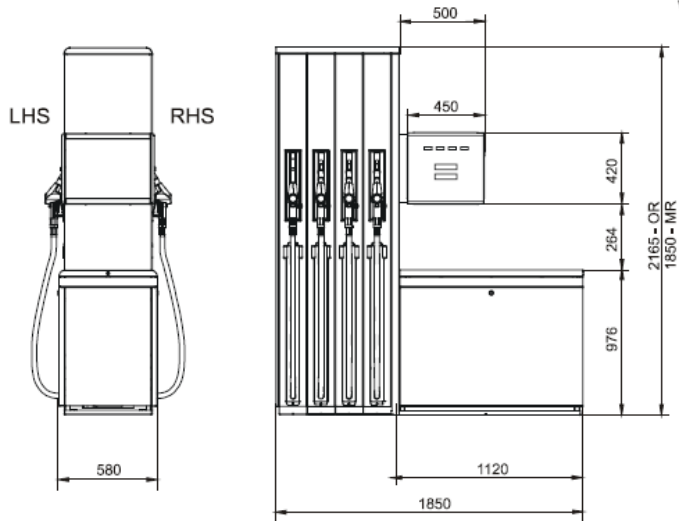

Valid only for C+ and Ecometer versions. Not for Multiplexed Ecometer

All Dimensions are in Millimetres

Option: Suction connection kit
140 826 683 without cathodic protection
140 826 693 with cathodic protection

Footprint Details Right Side of Dispenser (RHS)

Key to Symbols
A1- A4 - Grade 1, 2, 3, 4
B - Cable Riser
C - Vapour Recovery

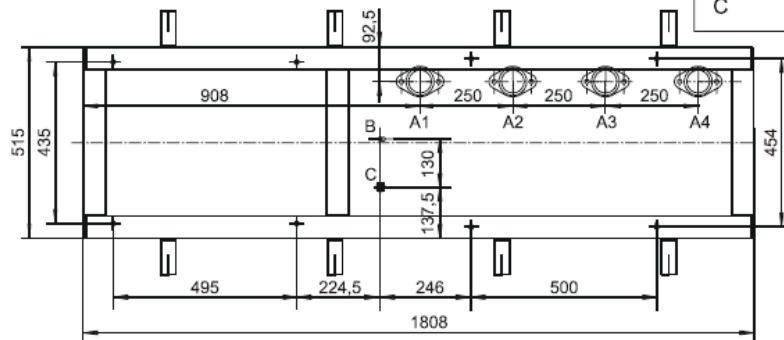

Subframe
Part No. - 140 733 432

*It is recommended that Vapour Recovery return pipes are installed where this may be a future requirement.

Module Configuration

Right Hand Side of Dispenser

